

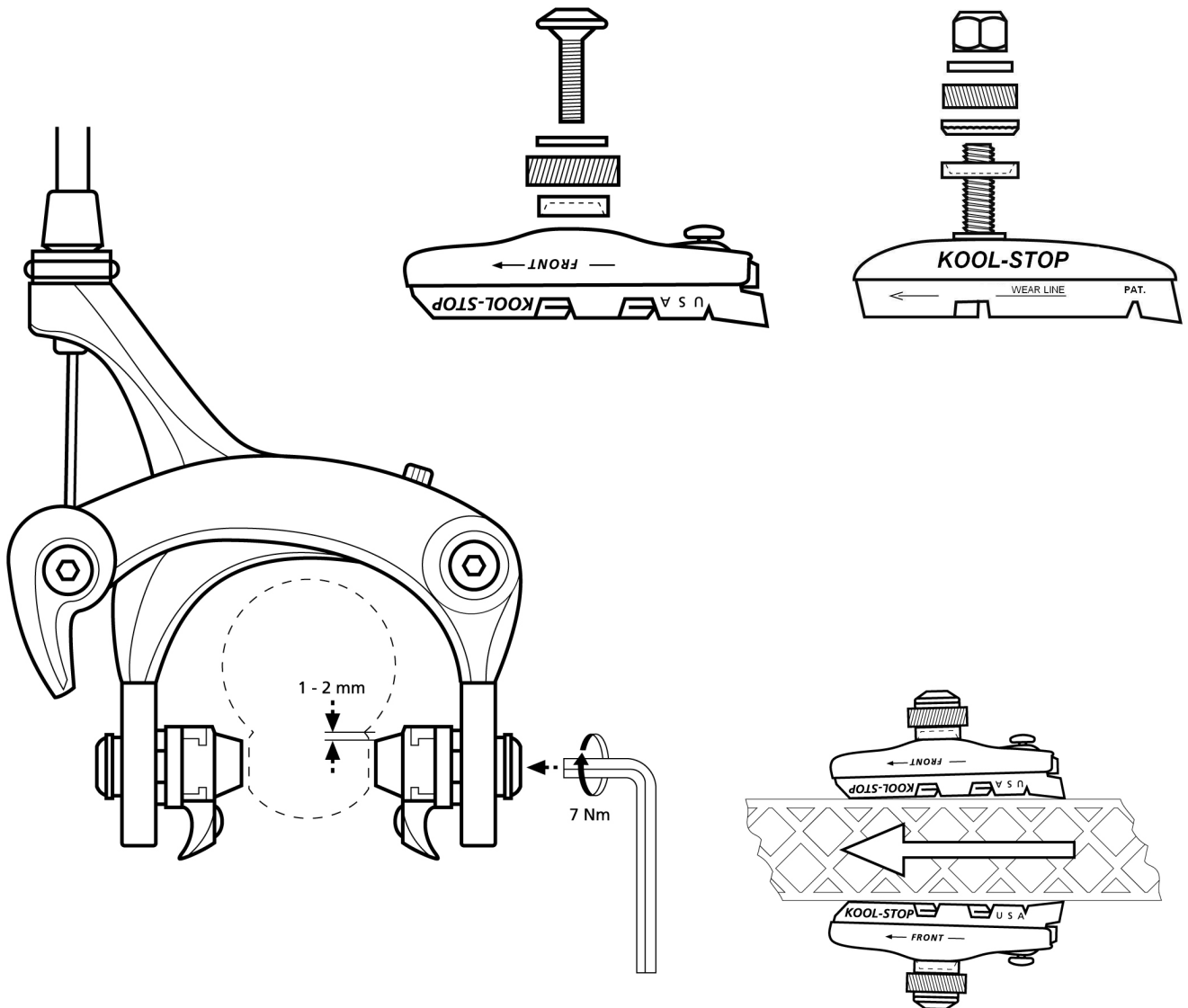

## INSTALLATION INSTRUCTIONS

### ROAD

- Koolite
- Dura Type
- Campi 2000
- Eagle 2™
- Vans®
- Continental



- Clean rim surface before installing new pads.
- Place new pads and finger tighten nuts.
- Align the pads correctly without touching the tire.
- Now tighten the nut with a force of 7 Nm.
- Check pad and rim alignment after the pads are broken in and after every ride.

**IMPORTANT:** Designed for bicycle use only. Do not ride bike until brakes are checked and functioning properly. All Kool-Stop Pads meet or exceed C.P.S.C. and D.I.N bicycle standards.