

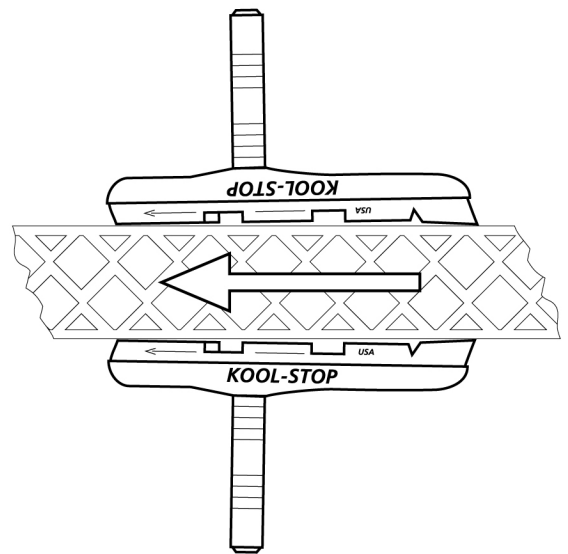

INSTALLATION INSTRUCTIONS

CANTILEVER

- Mountain Pad
- Eagle 2™
- Thinline™
- Phat Padd™
- Cross Holder

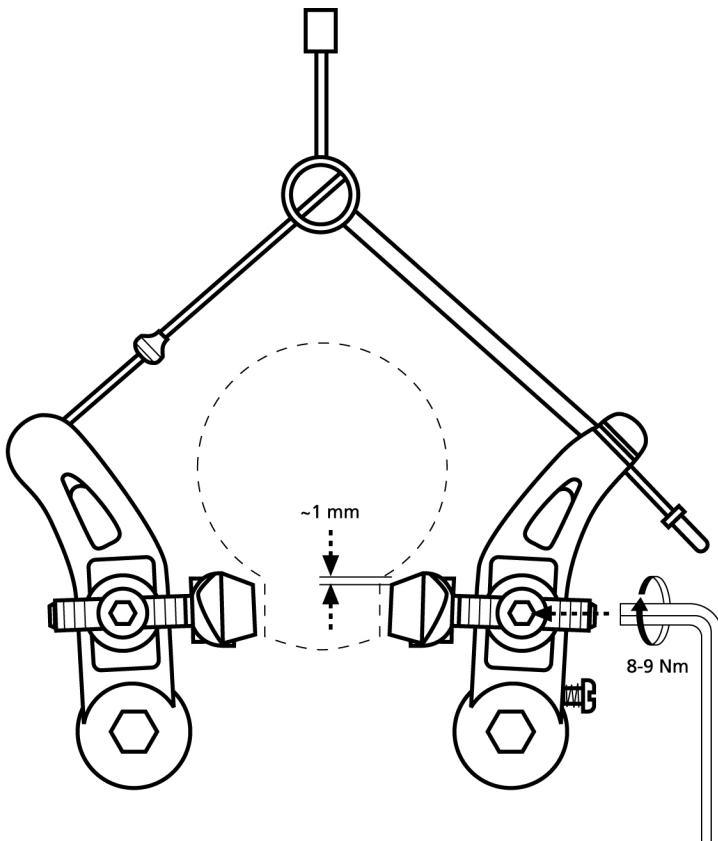
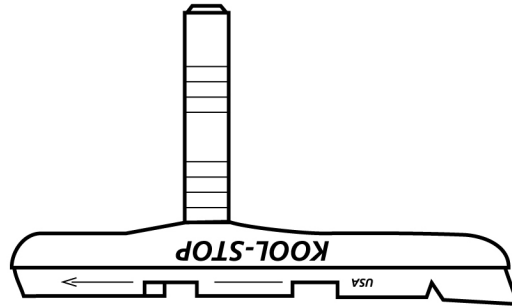

- Clean rim surface before installing new pads
- Place new pads and finger tighten nuts
- Align the pads correctly without touching the tire
- Now tighten the nut with a force of 8-9 Nm.
- Check pad and rim alignment after the pads are broken in and after every ride.

IMPORTANT: Designed for bicycle use only. Do not ride bike until brakes are checked and functioning properly. All Kool Stop Pads meet or exceed C.P.S.C. and D.I.N bicycle standards